

Evidence for Evolution

How are DNA and comparative anatomy used to show relatedness?

Why?

“You look just like your mother!” “He has his father’s eyes.” These comments that refer to the similarities between parents and their children are heard often in conversation. These similar traits are due to the genetic material that children inherit from their parents. As humans we are sometimes fortunate enough to have three or four generations sitting in a room at one time, and we can see the similarities from generation to generation. But how much do you look like your ancestors from 100 generations ago, 1000 generations ago or more? How much of your DNA did you inherit from those ancestors? What traits do you share with them?

Model 1 – Family Characteristics

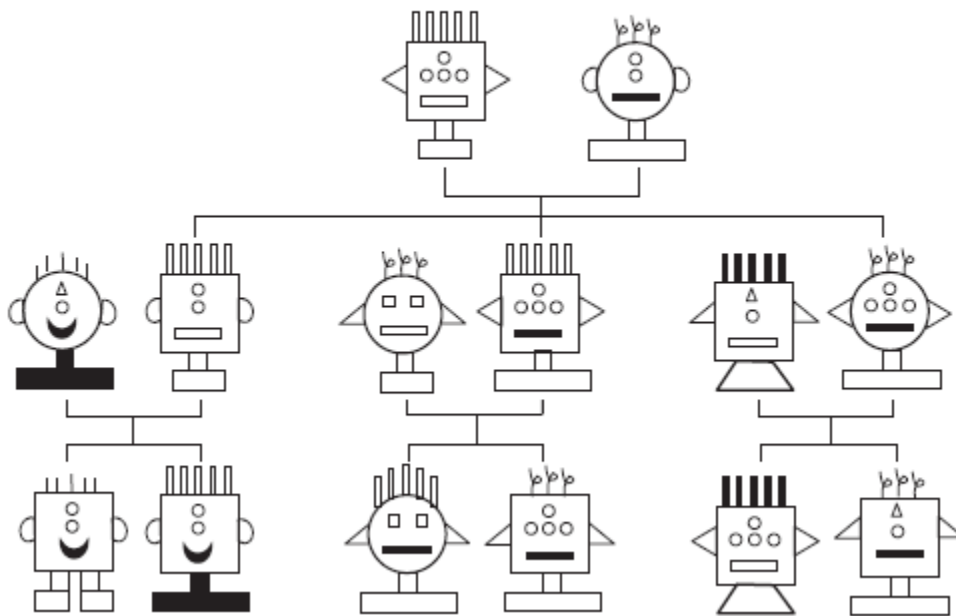

1. Model 1 is a family tree. Circle the original parents of the family.
2. How would you describe the organisms in the second row of Model 1 that are connected to the parents by a line?
3. Identify the three members of the family that “married in” by placing a star next to their figures in Model 1.
4. How are the organisms in the third line related to the organisms in the first line?
5. Consider the third generation of organisms in Model 1.
 - a. How many of the organisms in the third generation exhibit one or more traits identical to one of the grandparents?

- b. How did these traits get passed on through the generations from parent to offspring?
6. Consider the third generation of organisms in Model 1.
- How many of the organisms in the third generation exhibit one or more traits that are not shown in one of the grandparents?
 - Describe two methods by which these traits may have been introduced into the family tree.
7. In Model 1, which line of offspring shares the most traits with the parent organisms in the first line, the children or the grandchildren? Support your answer with evidence from Model 1.
8. In Model 1, which line of offspring shares the most DNA with the parent organisms in the first line, the children or the grandchildren?
9. Where did the original parent organisms in the first line in Model 1 get their traits?

Model 2 – Forelimb Similarities

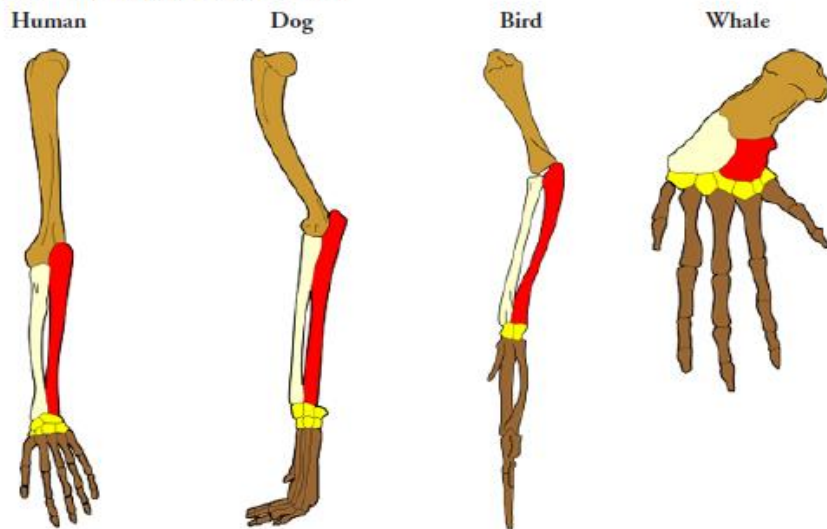

Number of Bones Found in the Forelimbs of Selected Animals				
Bone Name and Position	Human	Dog	Bird	Whale
Humerus—closest to body	1	1	1	1
Radius and Ulna	2, separate	2, separate	2, separate	2, separate
Carpals (wrist)—2nd joint	8	6	1–2	6
Metacarpals and Phalanges (fingers)—farthest from body	5	5	3	5

10. Label the bones in each animal forelimb in Model 2.
11. List the variety of ways in which the organisms in the table use their forelimbs.
12. Model 2 shows several homologous structures. These are limbs or body parts that are similar in structure due to shared ancestry, but that may be or may not be similar in function.
 - a. List two or more similarities in the bone structure of the four animals shown.
 - b. List three or more differences in the bone structure of the four animals shown.
13. Describe the location of the “blue print” that determines the structure of each of these forelimbs as the organism develops from embryo to infant.
14. What do the similarities among the forelimb bone arrangement of these diverse animals imply about their ancestry?
15. Which two animals in Model 2 would you predict have the most DNA sequences in common? Explain.

Read This!

Extensive research has been done to find similarities and differences in the DNA sequences of different animals. This work is very difficult and time consuming, but it can help biologists determine the evolutionary ancestry of a species. For example, when investigating the human genome, biologists found that about 99.5% of the DNA sequences among humans are the same. Considering the wide variety of traits in the human population, we are a lot more similar than we are different. Humans share approximately 96% of their DNA sequences with chimpanzees, 85% with mice, and 75% with chickens.

16. Study the table below.

Organism Pair	Percentage of DNA Similarity
A – B	97
A – C	85
A – D	50

- a. To which organism, B, C or D, is organism A most closely related? Support your answer.
- b. Which pair of organisms in the table is least closely related? Support your answer.
- c. Which pair of organisms most likely shares a recent common ancestor? Support your answer.

17. Suppose another organism, organism X, is discovered. Suggest how scientists would use DNA comparison to classify organism X?

Extension Questions

18. Refer to Model 2. Study the bone arrangement in the bird and whale. Propose an explanation for the similarity of elongated bone arrangement in the lower parts of the forelimb (metacarpals and phalanges), given the differences in the animals?
19. Thinking about how traits are inherited and considering the similarities in bone structure among the various animals in this activity, what might you expect to find if you compared the development of embryos among the organisms used in this activity?
20. Thinking about how traits are inherited, how would you explain the close similarities between the make-up of the oxygen-carrying molecule hemoglobin in organisms as diverse as birds, horses, gorillas, and humans?